

notiziario tecnico
installation wiring diagrams
instructions et schémas d'installation

elite
plus

**INTERCOMUNICAZIONE
MINIDOMOTICA**

**INTERCOMMUNICATION
BASIC DOMOTIC**

**INTERCOMMUNICATION
BASE DOMOTIQUE**

2008



AMPLYVOX



INTRODUCTION

Elite PLUS is a system patented by Amplyvox S.p.A. that it allows, through a 4 wires Bus line, to satisfy basic DOMOTIC services and, in case of code 3225/2EP, having also an advanced system of intercommunicating calls.

BASIC SMART HOUSE "MINIDOMOTICS":

The technology Elite PLUS allows to integrate to the functions of a normal intercom/monitor, with of commanding services functions. Addressed relays can be associated to the Elite PLUS intercom, connecting them in any point of the Bus line, to drive the required services. Services like stairs lights, shutters, blinds, switching music on/off etc can be commanded by selecting the number/letter of desired command on the display of the Elite PLUS intercom and pressing the key showing the light bulb on the left side of the display.

INTERCOMMUNICATION: (only for code 3225/2EP)

Elite PLUS has a system of calls digitization that allows to connect up to 16 intercommunicating devices by a 4 wire Bus and make calls each other through a display keypad located on the intercom/monitor cover with no need to have 16 call pushbuttons.

The practice and intuitive command keyboard and related display allow to recognize the ID No. of the calling intercom and, remaining visualized for 30 seconds, it simplifies callings back in case of delay in answering.

The INTERCOMMUNICATION function is only available using intercoms 3225/2EP into intercom systems with traditional wiring.

RELAY COMMAND PROCEDURE:

- Select ID No. of required relay scrolling addresses with "UP" and "DOWN" arrows.
- Send the command pressing the "bulb" button.

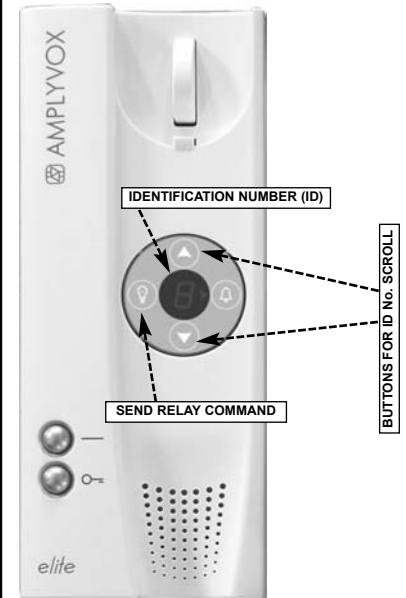

INTERCOM CALL PROCEDURE:

- Select ID No. of required telephone scrolling addresses with "UP" and "DOWN" arrows.
- Send the call pressing the "bell" button.

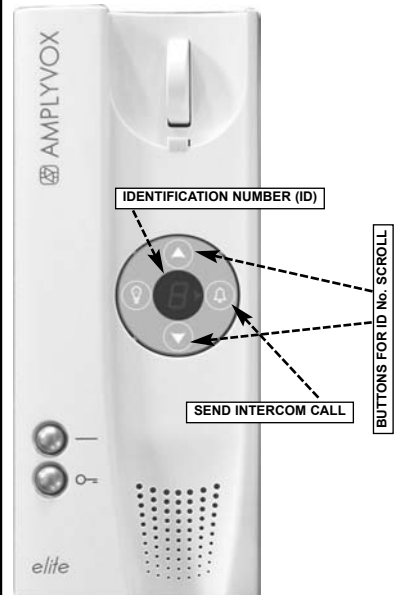

COMPONENTS:

CODE 3225/2EP

ELITE PLUS intercom telephone white, complete with PCB for intercommunicating services with traditional wiring (4+n wires), push-button for electric door lock release and push-button for auxiliary services (second door lock release, stairs lights, etc.), blue 7 segments display, 2 services signaling leds and 4 soft touch buttons for program selection. 2 different call tones for external and intercom calls, Vac buzzer for local door calls, 30 sec visualization of caller ID for intercom incoming calls, 10 sec storage of last called ID for intercom outgoing calls. Up to 16 ID address for intercommunicating telephones and 16 ID address for digital relays code 859/21PR for MINIDOMOTIC services are allowed in the system.

CODE 3G25/EP

ELITE PLUS cover white, fitted for ELITE models traditional wiring (4+n wires) code 3225, code 3325, simplified wiring (1+n wires) code 3725, code 3825 and digital wiring PROBUS-EVO (bus 2 wires) code 3A25, code 3B25. Complete with 7 segments blue display, 2 services signaling led and 4 soft touch buttons for program selection.

Up to 16 ID address for intercommunicating telephones and 16 ID address for digital relays code 859/21PR for MINIDOMOTIC services are allowed in the system.

NOTE: the usage for intercommunicating service is not possible with telephones not provided with intercommunication functions.

CODE 859/21PR

Programmable relay unit, complete with 2 independent relays.

The unit can be programmed by a dip-switch bank associating different addresses to each relay allowing independent commands. Each relay has also independent selection of working mode and timing.

NOTE: The two relay of the same units cannot have the same address and therefore cannot be controlled simultaneously!

Each relay is complete with

- NO/NC contact output
- working mode (monostable/bistable) switch
- trimmer for timer adjusting - Timer range 1-60 sec or 1-60 min.
- Led for status and proper functioning indications.

CODE 258/EP

Interface unit to drive automatic switch code 258N in intercommunicating system (traditional wiring) with entrance panel.

CODE 258/N

Automatic switch with modulator for audio intercom systems complete with entrance panel. *(please see also technical information "intercommunicating audio doorphones").*

- Input voltage: 12 V a.c.
- Output voltage: 12 V d.c. modulated (speech)
- Dimensions: 185 x 100 x 77 mm (11.5 DIN module)

CODE 236

Transformer for ELITE PLUS system

- Input voltage: 230 V a.c.
- Output voltage: 12 V a.c. - 15 VA
- Dimensions: 51 x 92 x 68 mm (3 DIN module)

COD. 237/1224

2 voltage outputs transformer for intercommunicating ELITE PLUS system.

- Input voltage: 230 V a.c.
- Output voltage 1: 12 V a.c. - 15 VA
- Output voltage 2: 24 V a.c. - 25 VA
- Dimensions: 88 x 94 x 68 mm (5 DIN module)

To be utilised in intercommunicating system (traditional wiring) with entrance panel in case of more than 3 telephone in parallel with same call from entrance panel. *(please see also technical information "intercommunicating audio doorphones").*

CODE 202

Power supply for intercommunicating ELITE PLUS system.

- Input voltage: 230 V a.c.
- Output voltage 1 : 15 V a.c. - 1,5 A
- Output voltage 2 : 9 V a.c. - 0,5 A
- Output voltage 3 : 12 V d.c. - 0,5 A
- Dimensions: 185 x 100 x 77 mm (11.5 DIN module)

To be utilised in intercommunicating system (traditional wiring) without entrance panel. *(please see also technical information "intercommunicating audio doorphones").*

CODE SUO/E

Internal additional tone generator for Elite telephones. To be installed inside ELITE telephones in intercommunicating system (traditional wiring) with entrance panel in case of more than 3 telephone in parallel with same call from entrance panel. *(please see also technical information "intercommunicating audio doorphones").*

CODE 853/2

External additional tone generator for Elite telephones. To be utilised in intercommunicating system (traditional wiring) with entrance panel in case of more than 3 telephone, with no SUO/E installed, in parallel with same call from entrance panel. *(please see also technical information "intercommunicating audio doorphones").*

CODE 2052/E

Amplified audio unit with electronic call for intercommunicating system (traditional wiring) with entrance panel. *(please see also technical information "intercommunicating audio doorphones").*

SYSTEM DIMENSIONING

WIRING STRUCTURE:

Devices of ELITE PLUS system are connected each other with a 4 wires polarized BUS (polarization MUST be respected!), and system limits are relate with:

- utilized cable type (section)
- distances between devices
- maximum number of devices utilized for the required sevice.

Suggested cable type:

Amplivox suggests to place cat. 5 cable utilizing 4 pairs to connect devices. The choice of cat. 5 cable is due to its structure and its availability on the market.

Distances between devices:

- max distance between the 2 farthest devices: 200 mt.
- max distance between transformer and farthest device: 150 mt.

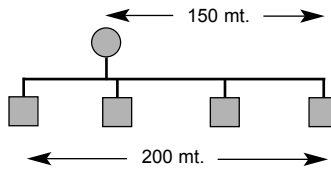

Calculation of maximum number of devices in the system:

The calculation of the maximum number of usable equipments depends on the system configuration. The limited consumptions guarantee wide possibilities of combinations using No. 1 transformer code 236 only but it is however necessary to ensure that the system is properly sized before power it on. The most simple and fast way for sizing verification is to download the practical software from the site www.amplivox.com and using it only after having carefully read this manual.

Another approximate, but practical way, for the calculation is to divide various elements that compose the system into 2 groups, distinguishing those who will be the command devices with (U) and those who will be the actuators with (R)

GROUP (U): code 3225/2EP and code 3G25/EP
GROUP (R): code 859/21PR

Indicative load values will be associated to elements of GROUP (U) and of GROUP (R) at rest condition (OFF) or at working condition (ON).

We will have:

Generic User at rest = (Uxx) OFF = 10

Generic User working = (Uxx) ON = 100

Being relay units code 859/21PR complete with 2 relays, they could have 3 specific values:

(R) OFF = 10 (Relay Unit with both relays at rest)

(R) ON/OFF = 100 (Relay Unit with one relay active and one relay at rest)

(R) ON = 150 (Relay Unit with both relays active)

LMax = 1300 = Single transformer code 236 load limit.

PART 1: DIMENSIONING SYSTEMS INTERCOMMUNICATING ONLY

Into an ELITE PLUS system up to 16 groups of intercommunicating telephones code 3225/2EP with different addresses can be connected.

Every group of intercoms can call another group remembering however that the system supports one conversation at time only and does not have privacy between telephones but only with the possible external panel.

With reference to the values previously described and indicating with 2 digits telephone ID, in case of single calls (without groups) we will have:

(Uxx) = generic user, (U01) = user 1, (U02) = user 2, (U03) = user 3, ..., (U16) = user 16

We assume the case that at each user, and therefore at each address, corresponds 1 telephone only.

The minimum consumption of the system will be calculated considering the total number of telephones multiplied for the unitary value at rest:

$$CU_{min} = 16 \text{ total telephones} \times 10 = 160$$

To calculate the maximum consumption of the system, consumption of users' conversation (in this case 2 users) and the active telephones will be added to minimum consumption Cmin:

$$CU_{max} = CU_{min} + \text{max users } q.ty (U) \text{ ON} = \\ 160 + 2 \text{ users } (U) \text{ ON} = \\ 160 + 2 \times 100 = 360$$

Being $360 < 1300$ we have verified that an ELITE PLUS system with 16 intercommunicating telephones code 3225/2EP set each one with its own address ID and then with maximum 2 devices working at same time is compliant with limits for a correct functioning.

Analyze the case when one or more users have multiple telephones in parallel and therefore more than one telephone set with same address ID.

Example 1:

16 users in total with:

user 1 (U01) with 1 telephone in parallel (2 telephones in total), and user 16 (U16) with 2 telephones in parallel (3 telephones in total).

Calculations must be made considering:

user 1 = (U01) x 2 telephones with same address
 user 16 = (U16) x 3 telephones with same address

$$CU_{min} = \text{total telephones } q.ty \times 10 = \\ 19 \text{ telephones} \times 10 = 190$$

$190 < 1300$ the system at rest works correctly.





Making now CUmax calculation:

max consumption occurs when user 1 calls user 16 because 5 telephones are active and load the system at same time.

$$CU_{max} = CU_{min} + \text{max active Users } U (ON) \text{ } q.ty = \\ 190 + (U01) \times 2 \text{ ON} + (U16) \times 3 \text{ ON} = \\ 190 + (2 \times 100) + (3 \times 100) = 690$$





$690 < 1300$ the system works properly!

EXAMPLE 1

	Qty	(U)off	(U)on	CUmax
 (U01)	2	20	200	200
 (U02)	1	10	100	-
 (...)	-
 (U15)	1	10	100	-
 (U16)	3	30	300	300
CUmin		190		
CUmax		190		500

690 < 1300 Compliant



EXAMPLE 2

	Qty	(U)off	(U)on	CUmax
 (U01)	7	70	700	700
 (U02)	1	10	200	-
 (...)	-
 (U15)	1	10	200	-
 (U16)	5	50	500	500
CUmin		260		
CUmax		260		1200

1460 > 1300 Not compliant

EXAMPLE 4

Only in this example, for simplicity of understanding consumption of the intercoms that are necessary for activating the relays, and without which the system doesn't have sense to exist, has not been calculated.

	Ra	Rb	(R) OFF	(R) ON/OFF	(R) ON
 (R01)	ON	OFF	10	100	
 (R02)	ON	ON	10		150
 (R03)	ON	OFF	10	100	
CRmin			30		
CUmax			30	200	150

380 < 1300 Compliant

Example 2:

16 users in total with:
user 1 (U01) with 6 telephones in parallel (7 telephones in total), and user 16 (U16) with 4 telephones in parallel (5 telephones in total).

$CU_{min} = \text{total telephones } q.ty \times 10 =$
 $26 \text{ telephones} \times 10 = 260$

$190 < 1300$ the system at rest works correctly.

Making now CU_{max} calculation:
max consumption occurs when user 1 calls user 16 because 5 telephones are active and load the system at same time.

$CU_{max} = CU_{min} + \text{max active Users } U \text{ (ON)} q.ty =$
 $260 + (U01) \times 7 \text{ ON} + (U16) \times 5 \text{ ON} =$
 $260 + (7 \times 100) + (5 \times 100) = 1460$

$1460 > 1300$ the system DOES NOT WORK! (see section "SYSTEM EXPANSION")

PART 2: DIMENSIONING SYSTEMS BASIC DOMOTIC ONLY

Intercom telephone code 3225/2EP and the cover code 3G25/EP can, by a BUS system, control relay units code 859/21PR having main domotics functions available, for example, stairs lights control, electric door locks, shutters, gates, etc...

Both telephones code 3225/2EP and covers code 3G25/EP allows to control 16 different addresses; a group of relay can be associated at same address respecting system capacity limits.

Due that each relay unit (R) code 859/21PR is complete with 2 relays with independent programming, this 2 internal relay (Ra) and (Rb) may result in 3 different values, to be utilised in dimensioning, depending on their working state (rest OFF, active ON):

(R) OFF = (Ra) OFF and (Rb) OFF = 10
(R) ON/OFF = (Ra) OFF and (Rb) ON
= (Ra) ON and (Rb) OFF = 100
(R) ON = (Ra) ON and (Rb) ON = 150

Note: for dimensioning calculation it is not important whether the two relays (Ra) and (Rb) have or not the same address but must be considered whether or not they work at the same time.

For CR_{min} and CR_{max} calculation it will be:
 $CR_{min} = \text{total relay units (R)} q.ty \times 10$
 $CR_{max} = \text{Sum (R) OFF} + \text{Sum (R) ON/OFF} + \text{Sum (R) ON}$

Example 3:

Connecting one relay unit (R) code 859/21EP No. 2 relays (Ra) and (Rb) will be available to control two services.

(Ra) stairs light (timed 10 sec.)
(Rb) automatic irrigation (timed 30 min.)

$CR_{min} = \text{total relay units (R)} q.ty \times 10 = 1 \times 10 = 10$

Max consumption C_{max} will be when stair light and automatic irrigation work contemporarily, so when

$CR_{max} = (Ra) \text{ ON and } (Rb) \text{ ON} = 150$

Being CR_{min} and $CR_{max} < 1300$ the system works properly.

Example 4:

Connecting 3 relay units (R1), (R2), (R3), code 859/21EP No. 6 relays will be available to control 6 services

(R1) =
(Ra) car gate opening (bistable)
(Rb) car gate closing (bistabile)

(R2) =
(Ra) garage light (timed 10 sec.)
(Rb) automatic irrigation (timed 30 min.)

(R3) =
(Ra) garage shutter opening (bistable)
(Rb) garage shutter closing (bistable)

$CR_{min} = \text{total relay units (R)} q.ty \times 10 =$
 $3 \times 10 = 30$

$CR_{max} = CR_{min} + \text{Sum (R) ON/OFF} + \text{Sum (R) ON}$

(R1) and (R3) will be calculated in ON/OFF status because 2 relays of each unit cannot work contemporarily but (R2) will be calculated in ON status because 2 relays of this unit may work contemporarily.

(R1) ON/OFF = 100
(R2) ON = 150
(R3) ON/OFF = 100

$CR_{max} = 30 + 200 + 150 = 380$

Being CR_{min} and $CR_{max} < 1300$ also in this case the system works properly.

PART 3: DIMENSIONING SYSTEMS INTERCOMMUNICATING AND BASIC DOMOTICS SERVICES (COMPLETE SYSTEM)

The telephone code 3225/2EP, besides the possibility of managing the service intercommunication between users can use the display to control home automation basic services.

Of course, in the calculation of consumption will take into account the combined consumption of intercommunication services and services for home automation shown in the previous paragraphs.

$CT_{min} = CU_{min} + CR_{min} =$
 $\text{total telephones } q.ty \times 10 + \text{total relay units (R)} q.ty \times 10$



$C_{max} = CU_{max} + CR_{max} =$
 $CT_{min} + \text{max active Users } U \text{ (ON)} q.ty + \text{Sum (R) ON/OFF} + \text{Sum (R) ON}$



Example 5:

Consider a house with 3 floors, as follows:
Floor G: No. 2 intercommunicating telephones code 3225/2EP in parallel (same address U01)
Floor 1: No. 1 intercommunicating telephone code 3225/2EP (address U02)
Floor 2: No. 2 intercommunicating telephones code 3225/2EP (address U03)
with No. 2 relay units code 859/21EP for controlling the following services:

(R1) = code 859/21EP with
Ra = Relay for ON/OFF irrigation system
Rb = Relay for stairs light switching

EXAMPLE 5

	Qty	(U)off	(U)on	CUmax
 (U01)	2	20	200	200
 (U02)	1	10	100	-
 (U03)	2	20	200	200
CUmin		50		
CUmax		50		400

	Rx	Rx	(R) OFF	(R) ON/OFF	(R) ON
 (R01)	ON	ON	10		150
 (R02)	ON	OFF	10	100	
CRmin			20		
CUmax			20	100	150

$$C_{max} = 70 + 400 + 100 + 150 = 720$$

C_{max} < 1300 Compliant

(R2) = code 859/21EP with
 Ra = Relay for car gate opening
 Rb = Relay for car gate closing

CTmin = CUmin + CRmin =
 total telephones q.ty x 10 + total relay units (R) q.ty x 10 = 70

Max consumption will occur when the user on the ground floor is communicating with the user on the 2nd floor while the two relay units are in working condition.

Note: (R1) may have the relay Ra and Rb simultaneously in state ON, while (R2) can not have the relay Ra and Rb simultaneously in state ON

for the calculation will be therefore:

(R1)ON= 150
 (R2)ON/OFF= 100

Cmax = CUmax + CRmax =
 CTmin + max active Users U (ON) q.ty + Sum (R) ON/OFF + Sum (R) ON =
 70 + (4 x 100) + (1 x 100) + (1 x 150) = 720

720 < 1300 the system works properly!

SYSTEM EXPANSION: STRUCTURE WITH MULTIPLE TRANSFORMERS CODE 236

To avoid malfunctionings in case of loads higher or close to the max system limits, simply insert another transformer in the line and distribute the loads in equitable way.

If for example system Cmax was = 2600, the best situation would be as follows:

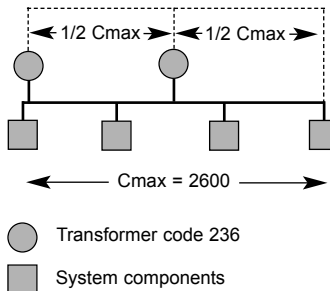

FINAL CONSIDERATIONS ABOUT DIMENSIONING AND SOME EXAMPLES OF CORRECTLY SIZED SYSTEMS

Listed below for convenience there are some examples of possible system configurations operating with a single transformer code 236:

users quantity	telephone quantity per user	relay units 859/21PR quantity	RESULTING Cmax < 1300
1	1	7	1230
1	2	6	1180
1	3	6	1290
1	4	5	1240
2	1	6	1180
2	2	5	1240
2	3	4	1300
2	4	2	1200
3	1	6	1190
3	2	5	1260
3	3	3	1170
3	4	2	1240
4	1	6	1200
4	2	5	1280
4	3	3	1200
4	4	2	1280

The above table shows that, although the number of relay units significantly affects the calculation of Cmax, the system with a single transformer code 236 offers wide possibilities of combinations, keeping in mind that each relay unit indicated in the table includes 2 separately programmable relays.

Here below there is for convenience a summary table including all abbreviations utilised along the dimensioning calculation examples and related associated values.

SUMMARY TABLE

SYMBOL	DESCRIPTION	VALUE
U(xx) ON	Generic active User	100
U(xx) OFF	Generic passive User	10
R(ON)	Relay Unit code 859/21PR with both relays active	150
R(OFF)	Relay Unit code 859/21PR with both relays at rest	10
R(ON/OFF)	Relay Unit code 859/21PR with one relay active and one relay at rest	100
L max	System limit with a single transformer code 236	1300
(Rx)ON	Active state of a relay inside to unit code 859/21PR	
(Rx)OFF	Rest state of a relay inside to unit code 859/21PR	
CUmin	Min. Users consumption = total telephones q.ty x 10	
CUmax	Max. Users consumption = Cumin+ max active Users U (ON) q.ty x 100	
CRmin	Min. Relay Units consumption = total relay unit q.ty (R) x 10	
CRmax	Max. Relay Units consumption = CRmin + Sum (R) ON/OFF + Sum (R) ON	
Cmax	Max. complex system consumption = CUmax+CRmax	

BASIC SYSTEM BLOCK DIAGRAM

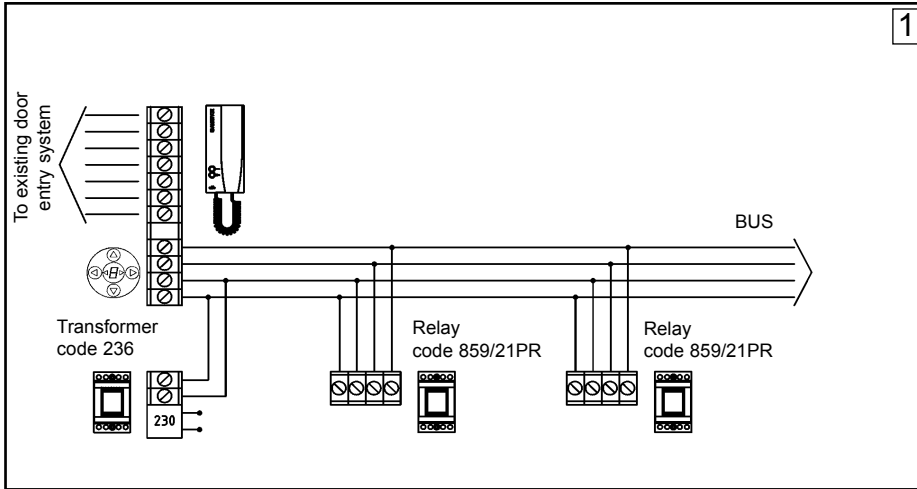

COMPLETE SYSTEM WITH 1 TRANSFORMER CODE 236 BLOCK DIAGRAM

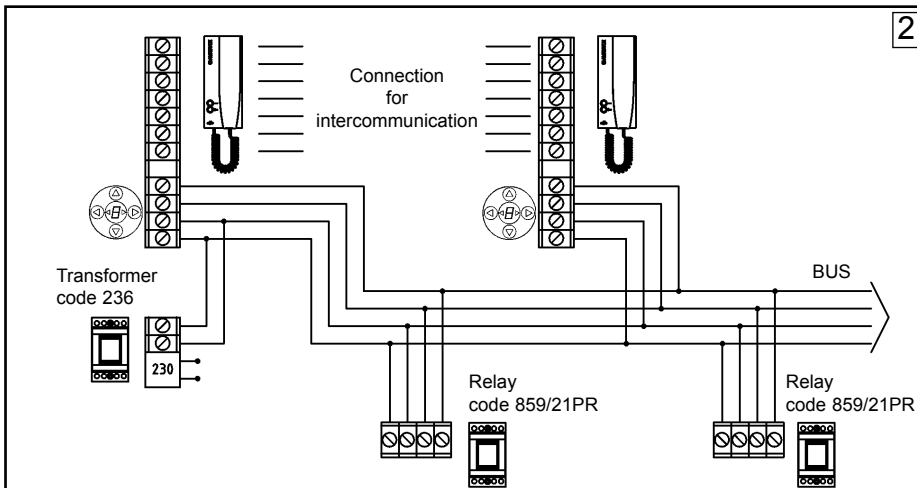

COMPLETE SYSTEM WITH MORE TRANSFORMERS CODE 236 BLOCK DIAGRAM

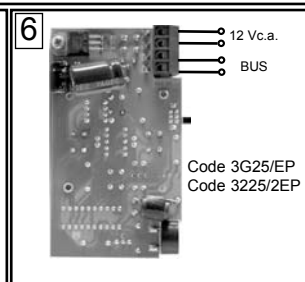
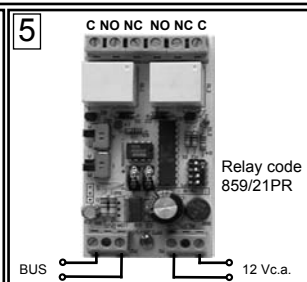
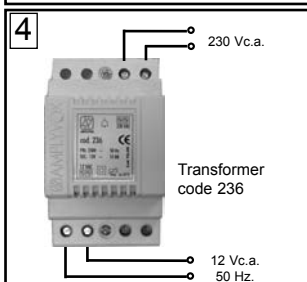
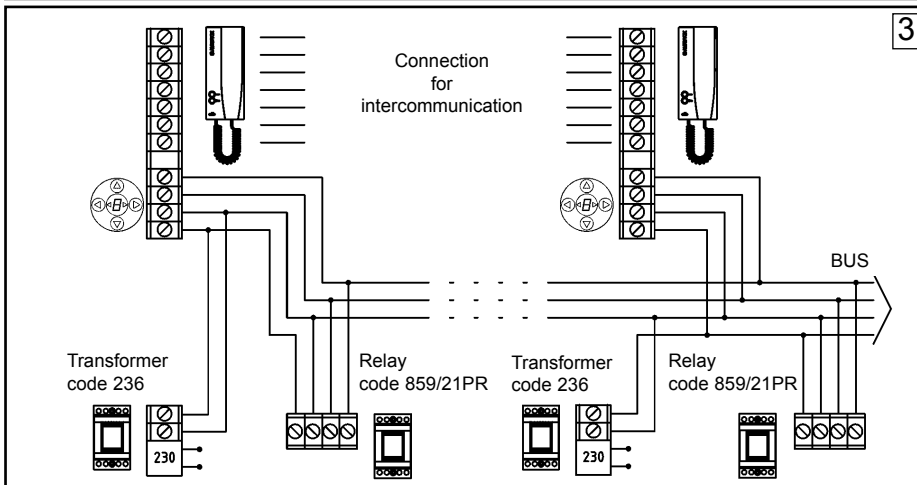

ELITE PLUS SYSTEM WIRINGS

The connection of equipment ELITE PLUS is made by a line BUS 4 wires.

The scheme of principle is shown in Pict. 1, all equipment can be connected on line BUS without any special care about position.

The transformer code 236 provides the power to the system. In case only one transformer is sufficient, it can be placed anywhere on the BUS line; in the case, however, the dimensioning requires more transformers in the same plant, it will be necessary to share the load evenly placing transformers in multiple points. (see page 5).

CAUTION: The transformer code 236 should only be used to supply the ELITE PLUS system.

As is shown in Pict.1 if the system ELITE PLUS is used only as MINIDOMOTICA, the management of relay is independent of the existing doorphone system. The only care will be choosing a telephone model compatible with the doorphone system technology.

The ELITE PLUS complete system shown in Pict. 2 however, highlights as an intercom system ELITE PLUS requires for voice-services the same connections of the traditional intercommunicating systems and the use of the 4 wires Bus line for the management of calls and relay units code 859/21PR.

In case the size of the system required multiple transformers code 236 the system structure will follow the principles shown in Pict. 3 taking care of placing transformers code 236 in order to distribute loads. (see page 5).

CONNECTIONS FUNCTIONS:

CODE 236

m.	Value	Function	Note
230Vac	230Vac	Main voltage input	Main
12Vac	12Vac	BUS power supply	max 1,3 A

CODE 859/21PR

m.	Value	Function	Note
GND	12Vac	Voltage input	
+12			
B1		BUS	
B2			
NO		RELAY A	Contact. NO
NC		RELAY A	Contact. NC
C		RELAY A	Common
NO		RELAY B	Contact. NO
NC		RELAY B	Contact. NC
C		RELAY B	Common

CODE 3225/2EP - COD. 3G25/EP

m.	Value	Function	Note
GND	12Vac	Voltage input	
+12			
B1		BUS	
B2			

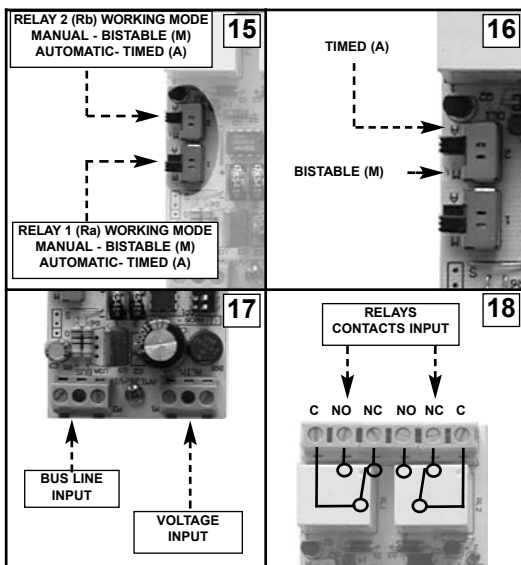
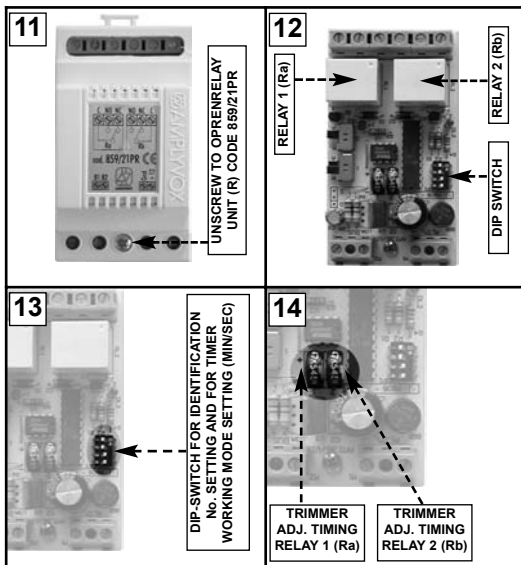
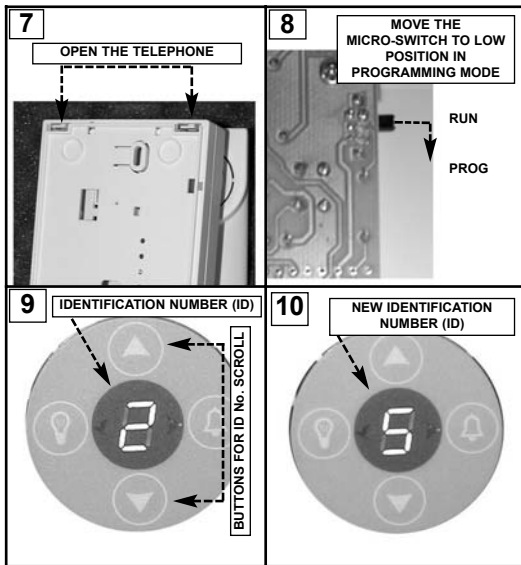

PROGRAMMING:

The programming must be carried out after being sure that the equipment has been properly connected and after having verified that the system is adequately designed for the use. After preliminary checks, switch on the system.

ID No. (address) setting in Elite Plus telephones

- 1) Open the telephone ELITE PLUS pressing the hooks placed on the back (Pict. 7)
- 2) Put the micro-switch in programming position (Pict. 8 - PROG), the display switches-on and shows the identification number of telephone (Pict. 9).
- 3) Scroll with the UP - DOWN keys until new address desired is shown (Pict. 10).

- 4) Move the programming switch back to RUN position.

Proceed in the same way to assign addresses to all Elite Plus telephones connected to the system.

Groups:

It is possible to assign the same address to several telephones to create groups of call: in these cases must pay special attention to consumption calculation as more calls are contemporary (refer to section "System dimensioning")

Programming of relay unit (R) code 859/21PR

- 1) Open the cover of the relay unit (R) unscrewing the locking screw (Pict. 11).
- 2) Assign the identification code to relay 1 (Ra) acting on Dip-switch 1,2,3, (Pict. 12 and Pict. 13) taking into account that the relay 2 (Rb), is set automatically on the subsequent number or letter set for the relay 1 (Ra); for example by setting the Dip-switch in position 0-0-0 the identification code 0 will be assigned to relay 1 (Ra) while the relay 2 (Rb) will be automatically assigned to identification code 1. With this setting, selecting on the telephone display the number 0 and pressing the symbol "bulb" the relay 1 (Ra) will be activated, while selecting on telephone display the number 1 will be activated the relay 2 (Rb).

Note: Two relays of same relay unit (R) code 859/21PR cannot have the same address and therefore they cannot be activated contemporarily by same command.

However, you can command more relays simultaneously using multiple relay units (R) with the same address (ID No.).

Ex: Setting the Dip-switch 0-0-0 of two relay units code 859/21PR and selecting display the number 0 both relays 1 (Ra) will be activated, while selecting on the telephone display the number 1 will be activated both relays 2 (Rb).

- 3) The relays 1 (Ra) and 2 (Rb) of the relay unit (R) code 859/21PR can work also as timed relay; the Dip-switch 4 (Pict. 13) set the "time" in minutes or seconds so that operating on trimmer 1 and 2 (Pict. 14) the timing can be adjusted from 1 to 60 seconds or from 1 to 60 minutes.

- 4) The working mode of each relay to operate as "bistable" (indicated by M on circuit board) or timed (indicated by A on circuit board) is defined by setting micro-switch Pict. 15 to the desired position (Pict. 16).

Below is the table of positions of Dip-switch for programming of relay units.

Relay unit (R)	Relay	ID No.	Dip-switch				Timer
			1	2	3	4	
1	1 (Ra)	0	0	0	0	min. sec.	
	2 (Rb)	1			1		
2	1 (Ra)	2	0	0	1	min. sec.	
	2 (Rb)	3			1		
3	1 (Ra)	4	0	1	0	min. sec.	
	2 (Rb)	5			1		
4	1 (Ra)	6	0	1	1	min. sec.	
	2 (Rb)	7			1		
5	1 (Ra)	8	1	0	0	min. sec.	
	2 (Rb)	9			1		
6	1 (Ra)	A	1	0	1	min. sec.	
	2 (Rb)	B			1		
7	1 (Ra)	C	1	1	0	min. sec.	
	2 (Rb)	D			1		
8	1 (Ra)	E	1	1	1	min. sec.	
	2 (Rb)	F			1		

DIP-SWITCH MAP

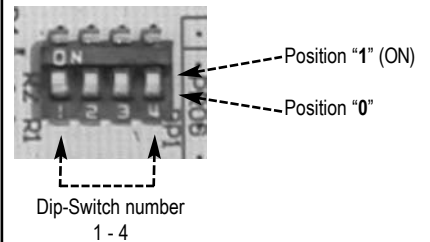

schemi di collegamento
wiring diagrams
schèmes d'installation

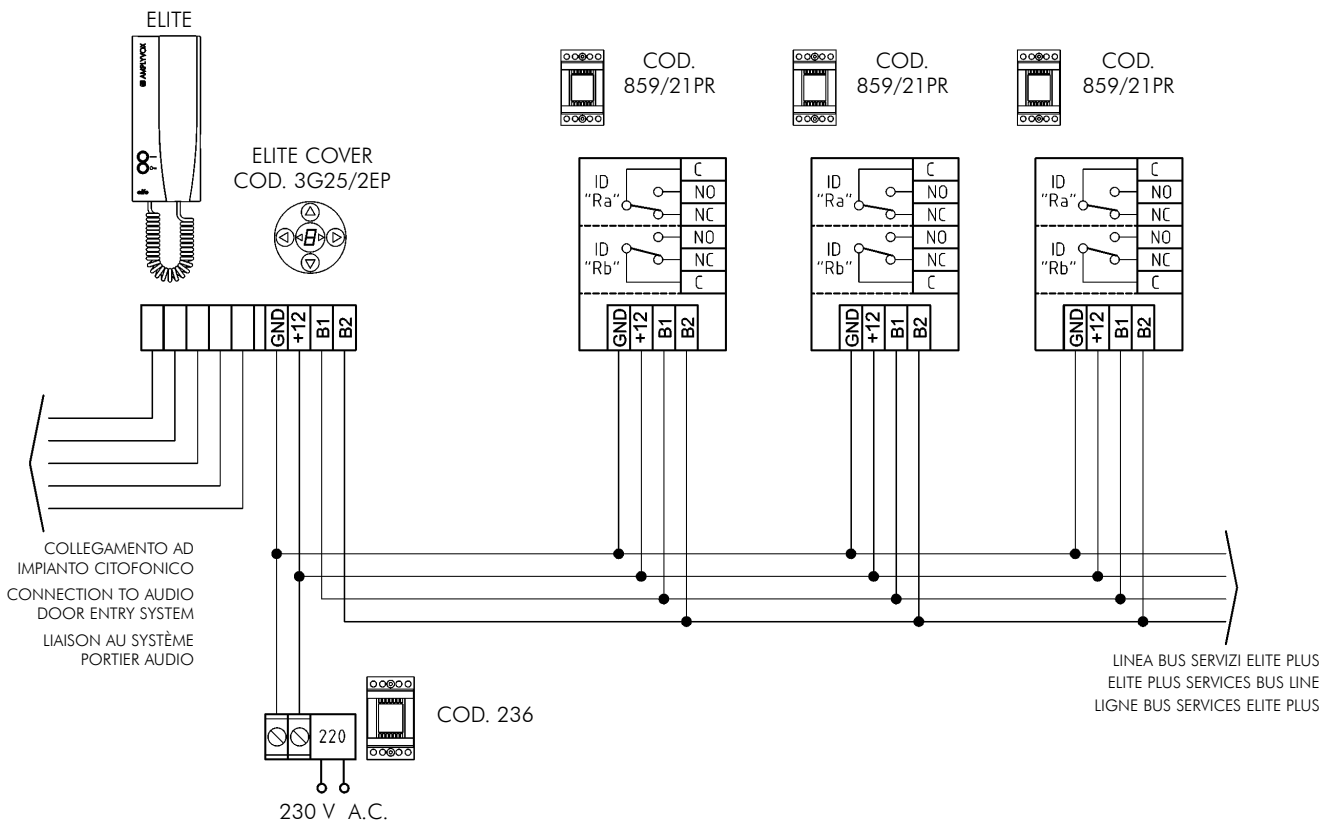

SCHEMI WIRING DIAGRAMS

Conduttori Wires - Fils	Lunghezza - Length - Longueur	
	100 mt	200 mt
—	Ø 0,5 mm ²	Ø 1,0 mm ²

COD. 236
 TRASFORMATORE
 TRANSFORMER
 TRANSFORMATEUR

COD. 859/21PR
 MODULO RELE' PROGRAMMABILE
 PROGRAMMABLE RELAY MODULE
 MODULE RELAIS PROGRAMMABLES

Impianto con cover Elite Plus e relè programmabili
 Smart house system with Elite Plus cover and programmable relays
 Système domotique avec cover Elite Plus et relais programmables

sch. 2724/01#

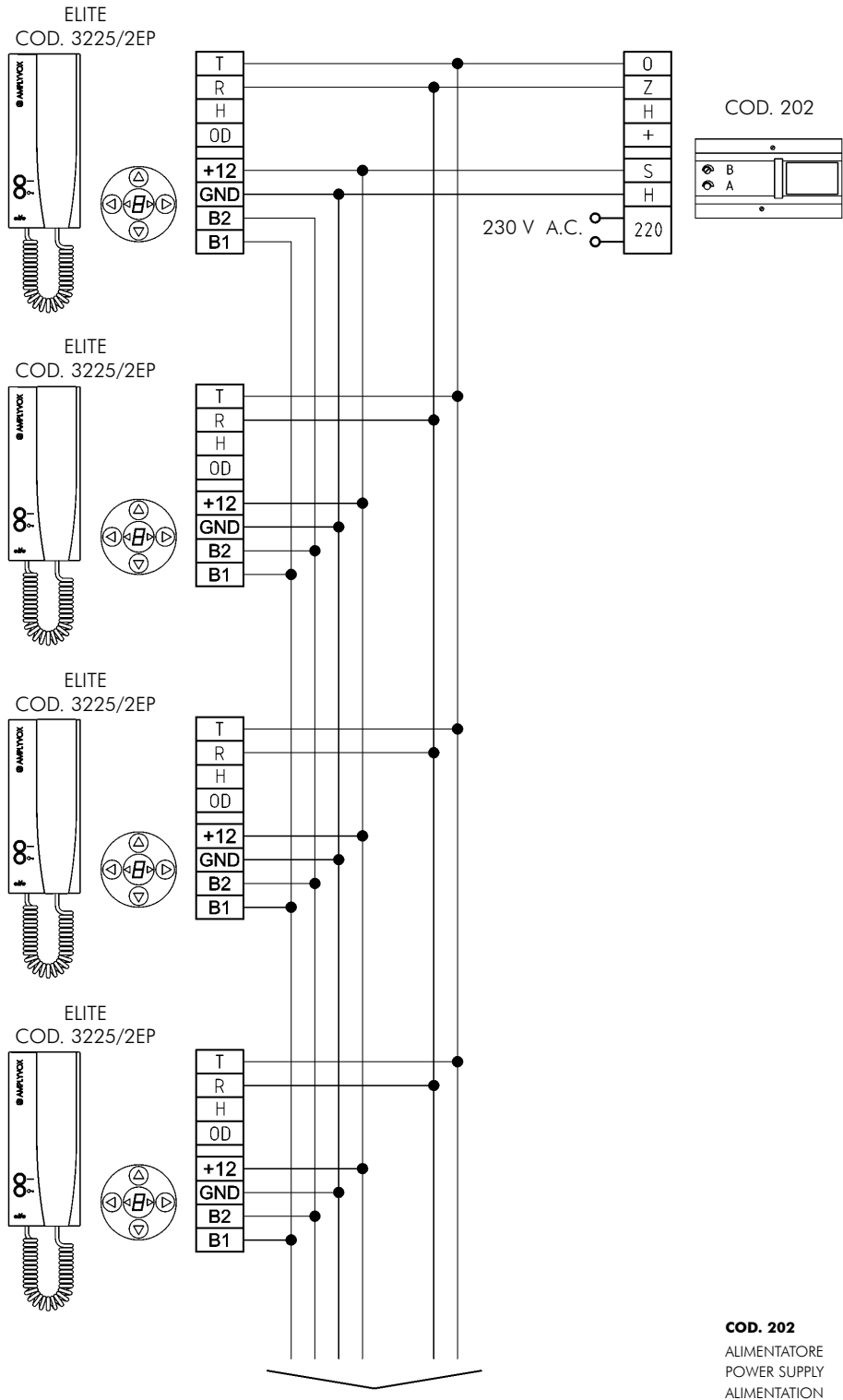

Conduttori Wires - Fils	Lunghezza - Length - Longueur	
	100 mt	200 mt
—	Ø 0,5 mm ²	Ø 1,0 mm ²

SCHEMI WIRING DIAGRAMS

Impianto intercomunicante senza posto esterno
 Intercommunicating system without door entry panel
 Système service intercom sans plaque de rue.

sch. 2713/01#

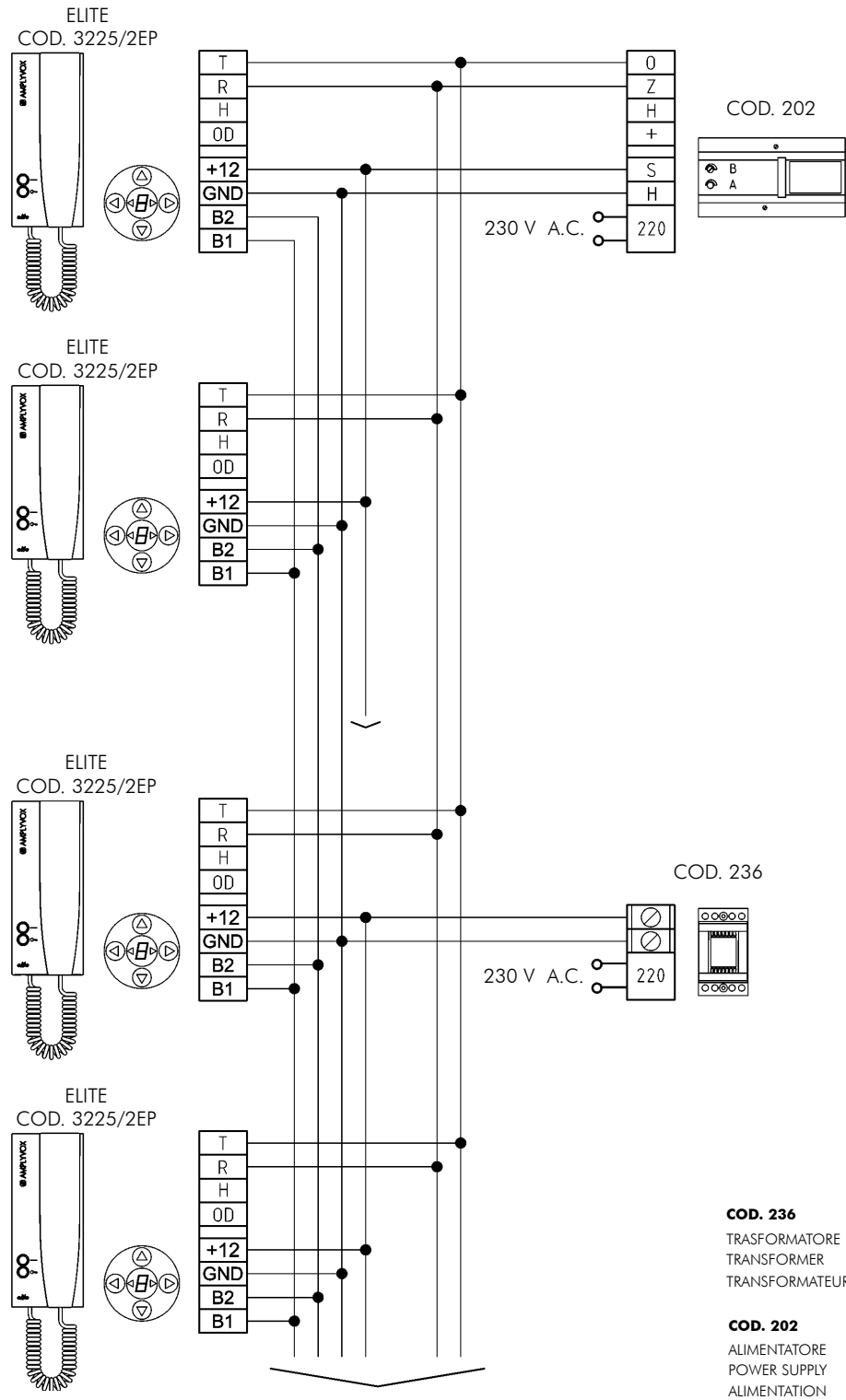

Conduttori Wires - Fils	Lunghezza - Length - Longueur	
	100 mt	200 mt
—	Ø 0,5 mm ²	Ø 1,0 mm ²

SCHEMI WIRING DIAGRAMS

COD. 236
 TRASFORMATORE
 TRANSFORMER
 TRANSFORMATEUR

COD. 202
 ALIMENTATORE
 POWER SUPPLY
 ALIMENTATION

Impianto intercomunicante senza posto esterno con alimentazione addizionale
 Intercommunicating system without door entry panel with additional power supply
 Système service intercom sans plaque de rue - Avec alimentation additionnelle

sch. 2713/02#



COD. 236

TRASFORMATORE
 TRANSFORMER
 TRANSFORMATEUR

COD. 258/N

COMMUTATORE
 AUTOMATIC SWITCH
 COMMUTEUR

COD. 258/EP

MODULO COMANDO
 COMMAND MODULE
 MODULE COMMANDEMENT

COD. 2052/E

POSTO ESTERNO
 AUDIO SPEAKER UNIT
 GROUPE PHONIQUE

S.E.

ELETTROSERRATURA
 ELECTRIC LOCK
 GACHE ELECTRIQUE

Y

PULSANTE APRIPORTA
 INTERNAL DOOR RELEASE
 POUSSOIR OUVRE PORTE

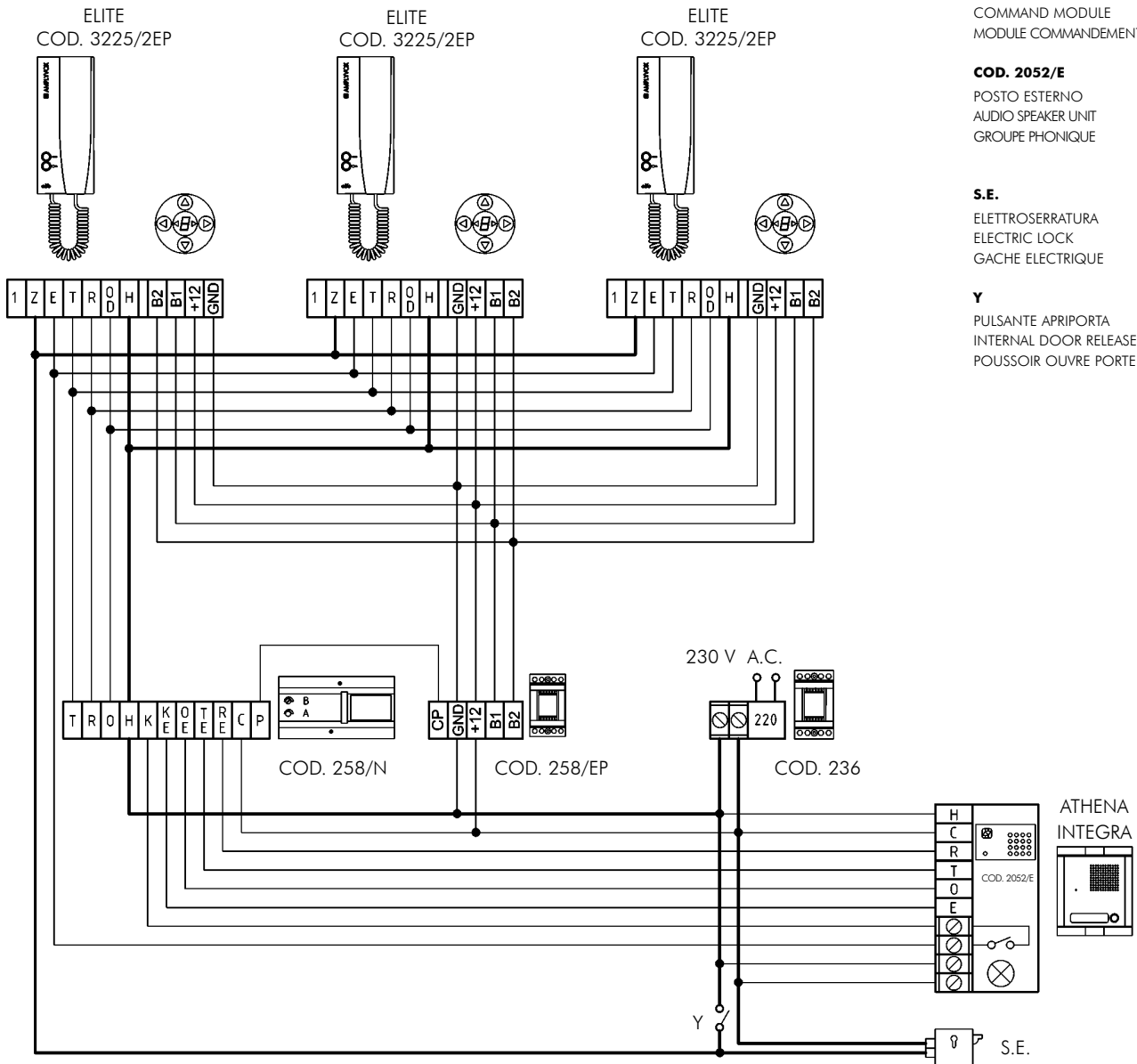

SCHEMI WIRING DIAGRAMS

Conduttori Wires - Fils	Lunghezza - Length - Longueur	
	100 mt	200 mt
	Ø 0,5 mm ²	Ø 1,0 mm ²
	Ø 0,75 mm ²	Ø 1,5 mm ²

Max 3 citofoni in parallelo per ogni chiamata esterna.
 Max 3 telephones in parallel for each external call.
 Max 3 combinées en parallèle par chaque appel extérieur.

Impianto monoutente intercomunicante con posto esterno
 Single user intercommunicating system with door entry panel
 Système 1 usager service intercom avec plaque de rue

sch. 2712/03#

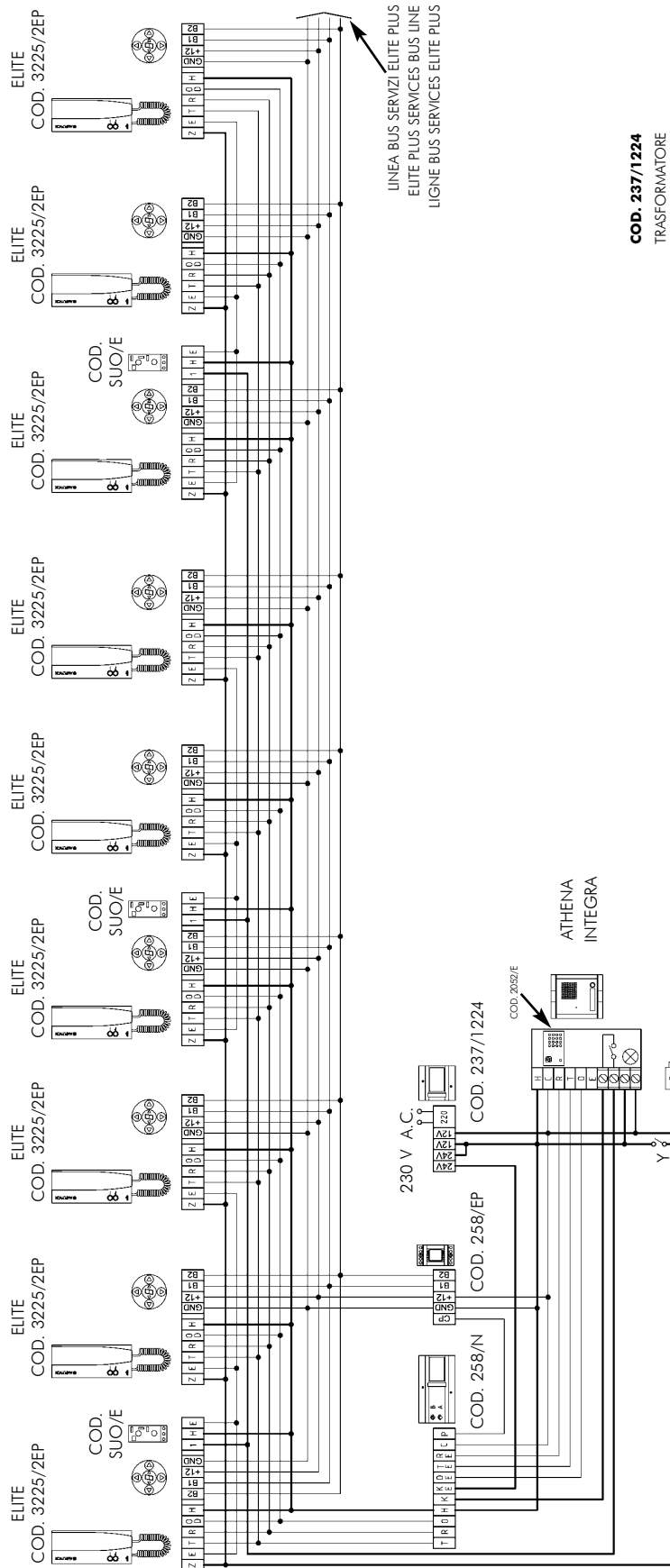

COD. 237/1224
TRASFORMATORE
TRANSFORMER
TRANSFORMATEUR

COD. 258/N
COMMUTATORE
AUTOMATIC SWICH
COMMUTATEUR

COD. 258/EP
MODULO COMANDO
COMMAND MODULE
MODULE COMMANDEMENT

COD. 2052/E

POSTO ESTERNO
AUDIO SPEAKER UNIT
GROUPE PHONIQUE

COD. 5UO/E

GENERATORE DI NOTA
TONE GENERATOR
GENERATEUR D'APPEL ELECTRONIQUE

S.E.

ELETTROSERRATURA
ELECTRIC LOCK
GACHE ELECTRIQUE

Y

PULSANTE APRIORTA
INTERNAL DOOR RELEASE
POUSOIR OUVERE PORTE

Conduttori Wires - Fils	Lunghezza - Length - Longueur
—	100 mt 200 mt
—	Ø 0,5 mm ² Ø 1,0 mm ²
—	Ø 0,75 mm ² Ø 1,5 mm ²

SCHEMI WIRING DIAGRAMS

Impianto intercomunicante con posto esterno con chiamata singola su più di 3 citofoni

Intercommunicating system with door entry panel - Single call to more than 3 telephones

Système service intercom avec plaque de rue - Un seul appel sur plus que 3 parlophones

sch. 2712/05#

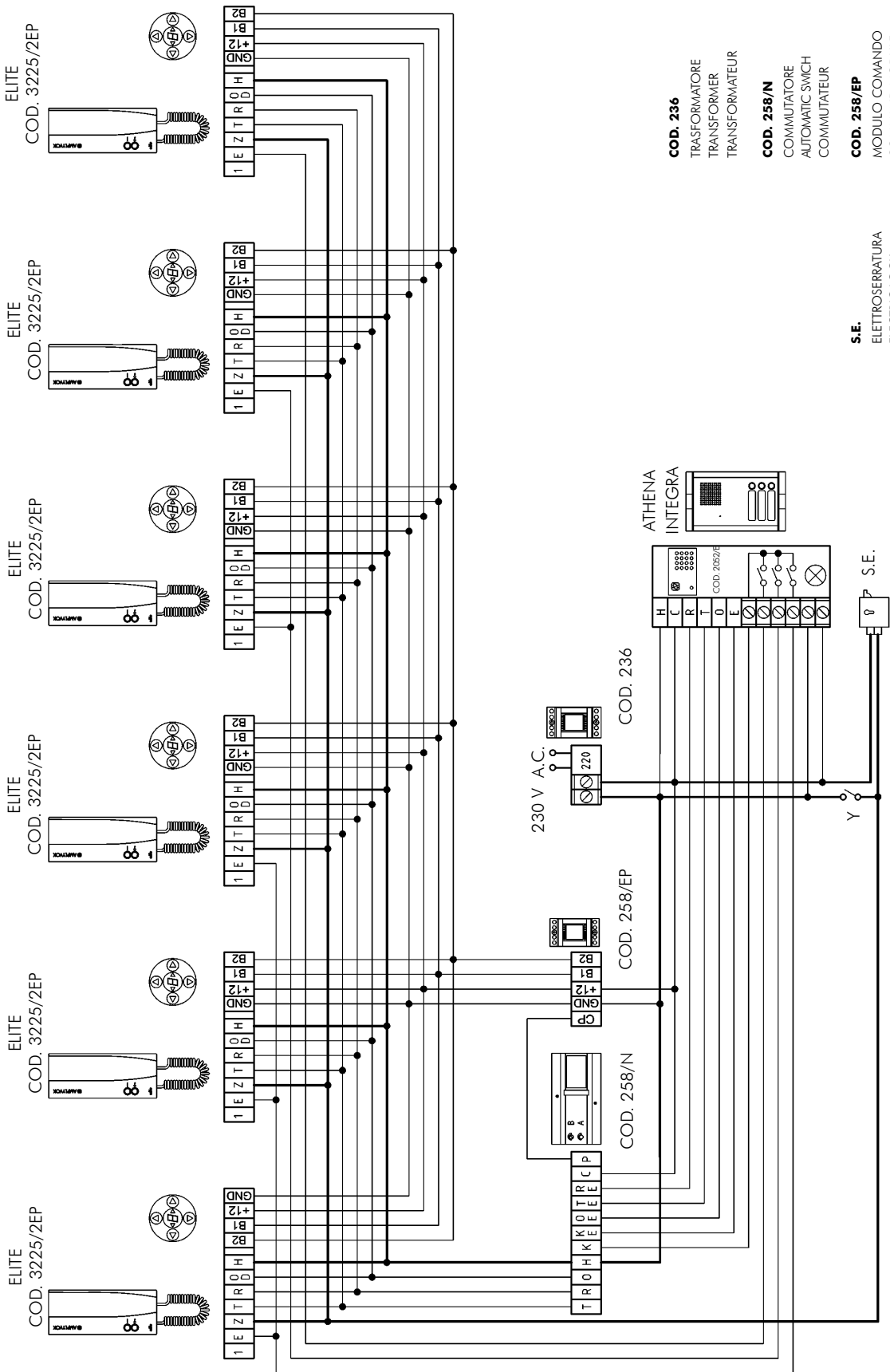

- COD. 236**
 TRASFORMATORE
 TRANSFORMER
 TRANSFORMATEUR
- COD. 258/N**
 COMMUTATORE
 AUTOMATIC SWITCH
 COMMUTEUR
- COD. 258/EP**
 MODULO COMANDO
 COMMAND MODULE
 MODULE COMMANDEMENT
- COD. 2052/E**
 POSTO ESTERNO
 AUDIO SPEAKER UNIT
 GROUPE PHONIQUE

- S.E.**
 ELETTROSERRATURA
 ELECTRIC LOCK
 GACHE ELECTRIQUE
- Y**
 PULSANTE APRIORTA
 INTERNAL DOOR RELEASE
 POUSSOIR OUVRE PORTE

Max 3 citofoni in parallelo per ogni chiamata esterna.
Max 3 telephones in parallel for each external call.
Max 3 combinées en parallèle par chaque appel extérieur.

Conduttori Wires - Fils	Lunghezza - Length - Longueur
—	100 mt 200 mt
—	Ø 0,5 mm ² Ø 1,0 mm ²
—	Ø 0,75 mm ² Ø 1,5 mm ²

SCHEMI WIRING DIAGRAMS

Impianto multiutente intercomunicante con posto esterno
 Multi users intercommunicating system with door entry panel
 Système multiples usagers service intercom avec plaque de rue
sch. 2712/04#

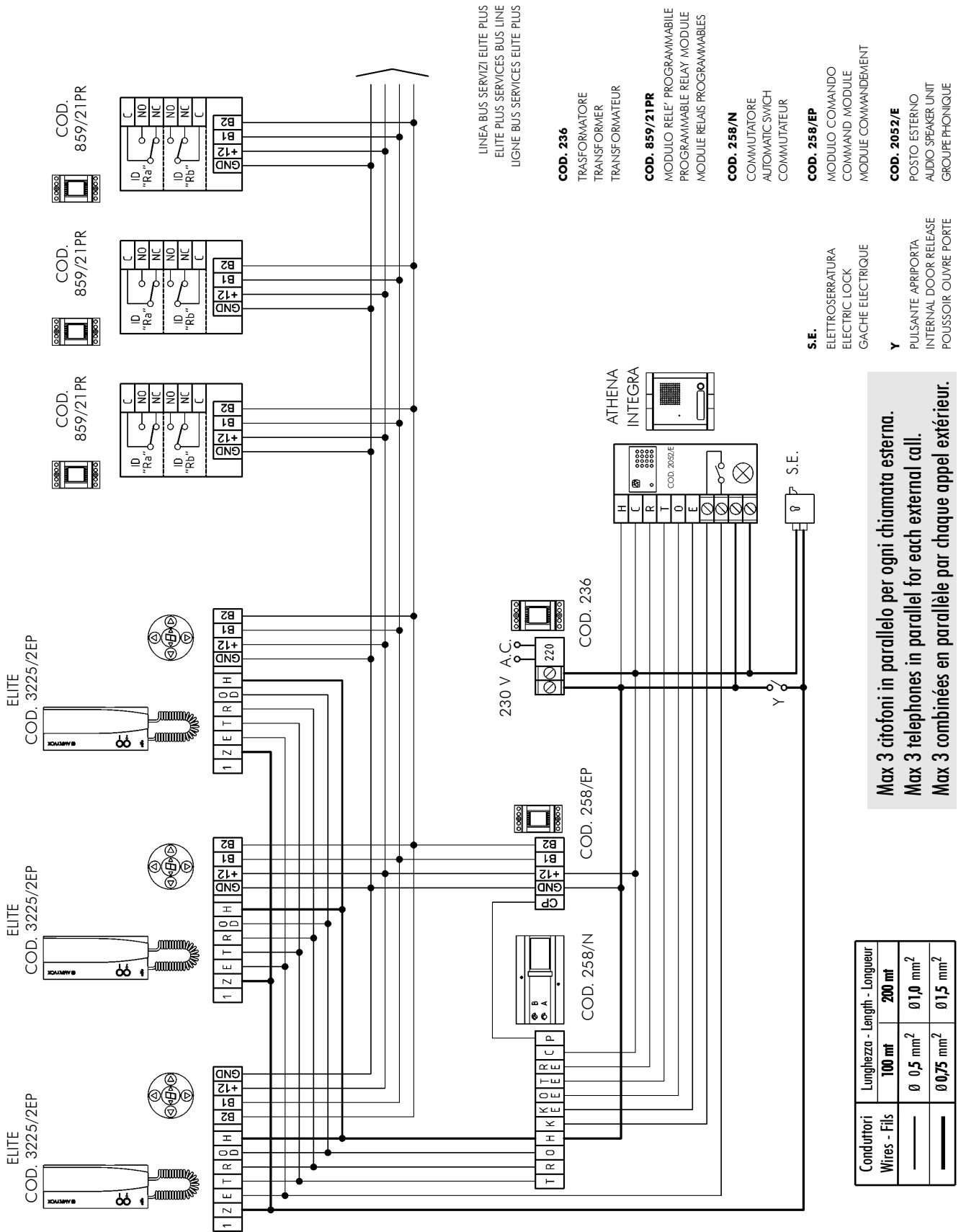

Max 3 citofoni in parallelo per ogni chiamata esterna.
Max 3 telephones in parallel for each external call.
Max 3 combinées en parallèle par chaque appel extérieur.

SCHEMI WIRING DIAGRAMS

Conduttori Wires - Fils	Lunghezza - Length - Longueur
—	100 mt 200 mt
—	Ø 0,5 mm ² Ø 1,0 mm ²
—	Ø 0,75 mm ² Ø 1,5 mm ²

Impianto monoutente intercomunicante con posto esterno e relè programmabili
 Single user intercommunicating system with door entry panel and programmable relays
 Système 1 usager service intercom avec plaque de rue et relais programmables

sch. 2722/01#



AMPLYVOX S.p.A.

Via G. Di Vittorio, 7
I 20063 CERNUSCO sul Naviglio (MI) Italy
Telefono +39.02.92.106.321
Fax +39.02.92.107.983
e-mail: tecnico@amplyvox.com
website: www.amplyvox.com

